

TEA2025

LINEAR INTEGRATED CIRCUIT

STEREO AUDIO AMPLIFIER

DESCRIPTION

The Contek TEA2025 is a monolithic integrated audio amplifier in a 16-pin plastic dual in line package. It is designed for portable cassette players and radios.

FEATURES

- *Working Voltage down to 3V
- *Few External components
- *High Channel isolation
- *Voltage gain up to 45dB(Adjustable with external resistor)
- *Soft clipping
- *Internal Thermal protection

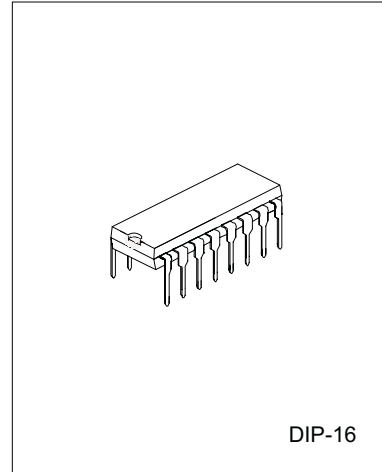

PIN CONFIGURATIONS

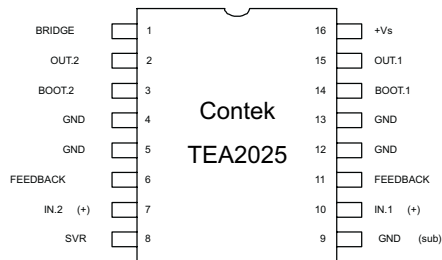

BLOCK DIAGRAM

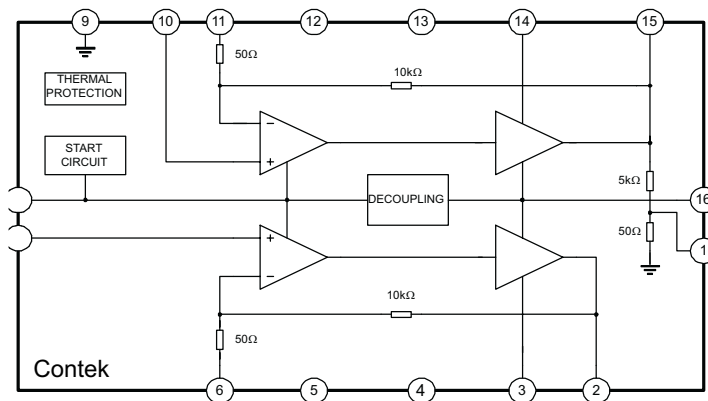

Contek Microelectronics Co.,Ltd.

<http://www.contek-ic.com> E-mail:sales@contek-ic.com

ABSOLUTE MAXIMUM RATINGS

PARAMETER	SYMBOL	VALUE	UNIT
Supply Voltage	Vs	15	V
Output Peak Current	Io	1.5	A
Junction Temperature	Tj	150	C
Storage Temperature	Tstg	-40 ~ +150	C

ELECTRICAL CHARACTERISTICS (Ta=25 C, Vcc=9V, Stereo, Unless otherwise specified)

PARAMETER	SYMBOL	TEST CONDITIONS	MIN	TYP	MAX	UNIT
Supply Voltage	Vs		3		12	V
Quiescent Current	Iq			40	50	mA
Quiescent output voltage	Vo			4.5		V
Voltage gain	Av	Stereo	43	45	47	dB
		Bridge	49	51	53	
Voltage gain difference	ΔAv				+1	dB
Input impedance	Ri			30		kΩ
Output Power	Po	f=1kHz; d=10% Stereo per channel Vcc=9V; RL=4Ω RL=8Ω	1.7	2.3 1.3		
		Vcc=6V; RL=4Ω RL=8Ω	0.7	1 0.6		W
		Vcc=3V; RL=4Ω		0.1		
		Bridge Vcc=9V; RL=8Ω		4.7		
		Vcc=6V; RL=4Ω		2.8		
Distortion	d	Vcc=9V; RL=4Ω f=1kHz; Po=250mW Stereo		0.3	1.5	%
		Bridge		0.5		
Supply voltage Rejection	SVR	Rg=0; Av=45dB Vripple=150mVRMS Fripple=100Hz	40	46		dB
Input noise Voltage	Vn	Av=200 Bandwidth: 20Hz to 20kHz Rg=0 Rg=10kΩ		1.5 3	3 6	μV
Cross-Talk	C.T.	Rg=10kΩ; f=1kHz; RL=4Ω Po=1W	40	55		dB



THERMAL RESISTANCE

Rth(j-c): Junction to case thermal resistance 15 C/W

Rth(j-a): Junction to ambient thermal resistance 60 C/W

TYPICAL PERFORMANCE CHARACTERISTICS

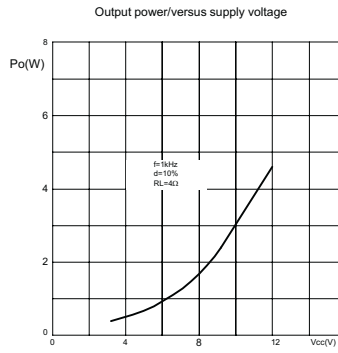
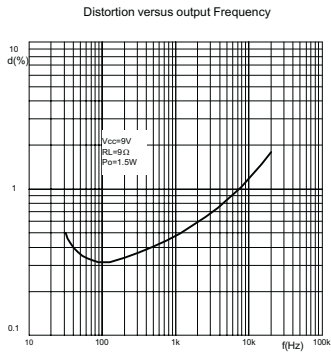
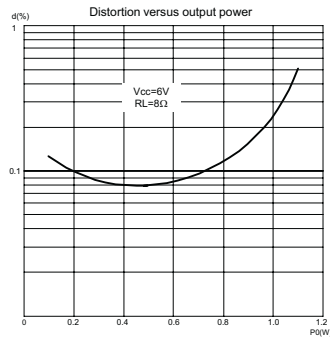
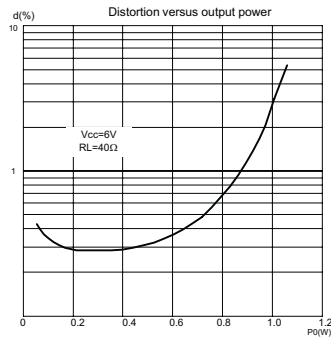

TEA2025

LINEAR INTEGRATED CIRCUIT

APPLICATION CIRCUIT

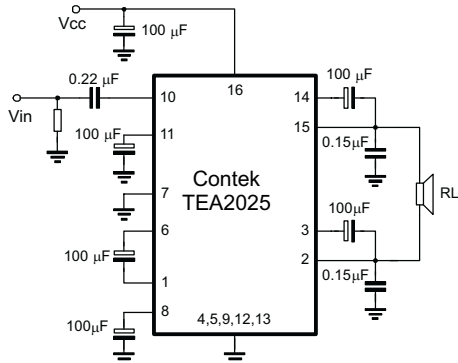

Fig. 5 Bridge Application

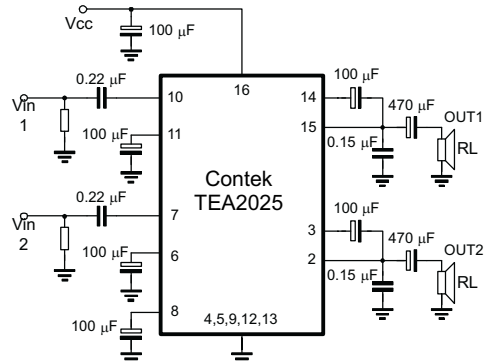
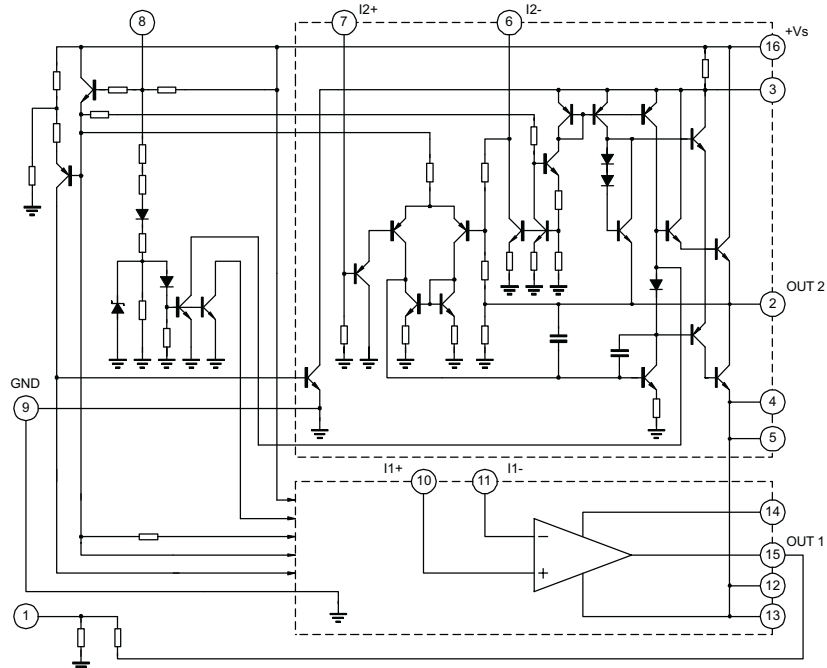

Fig.6 Stereo Application

SCHEMATIC DIAGRAM



Contek Microelectronics Co.,Ltd.

<http://www.contek-ic.com> E-mail:sales@contek-ic.com